

THIS DRAWING IS UNPUBLISHED. RELEASED FOR PUBLICATION .19
 © COPYRIGHT 19 BY AMP INCORPORATED. ALL RIGHTS RESERVED.

LOC	DIST	REVISIONS			
P	LTR	DESCRIPTION	DATE	DWN	APVD
AF	50	A	REV & REL PER 063A-0203-99	11OCT99	JR DD

1 CONTINUOUS STRIP ON REEL.

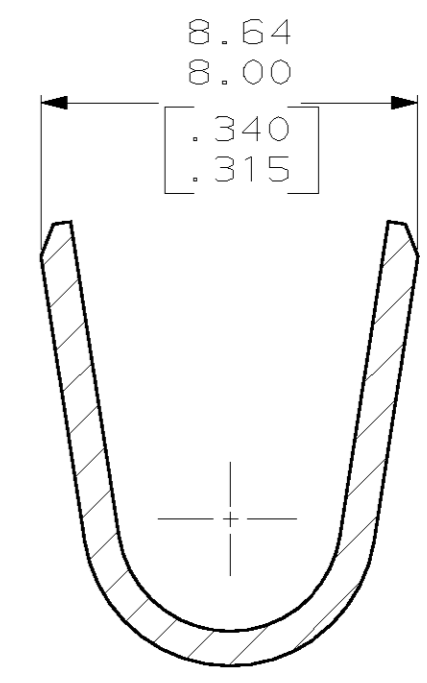
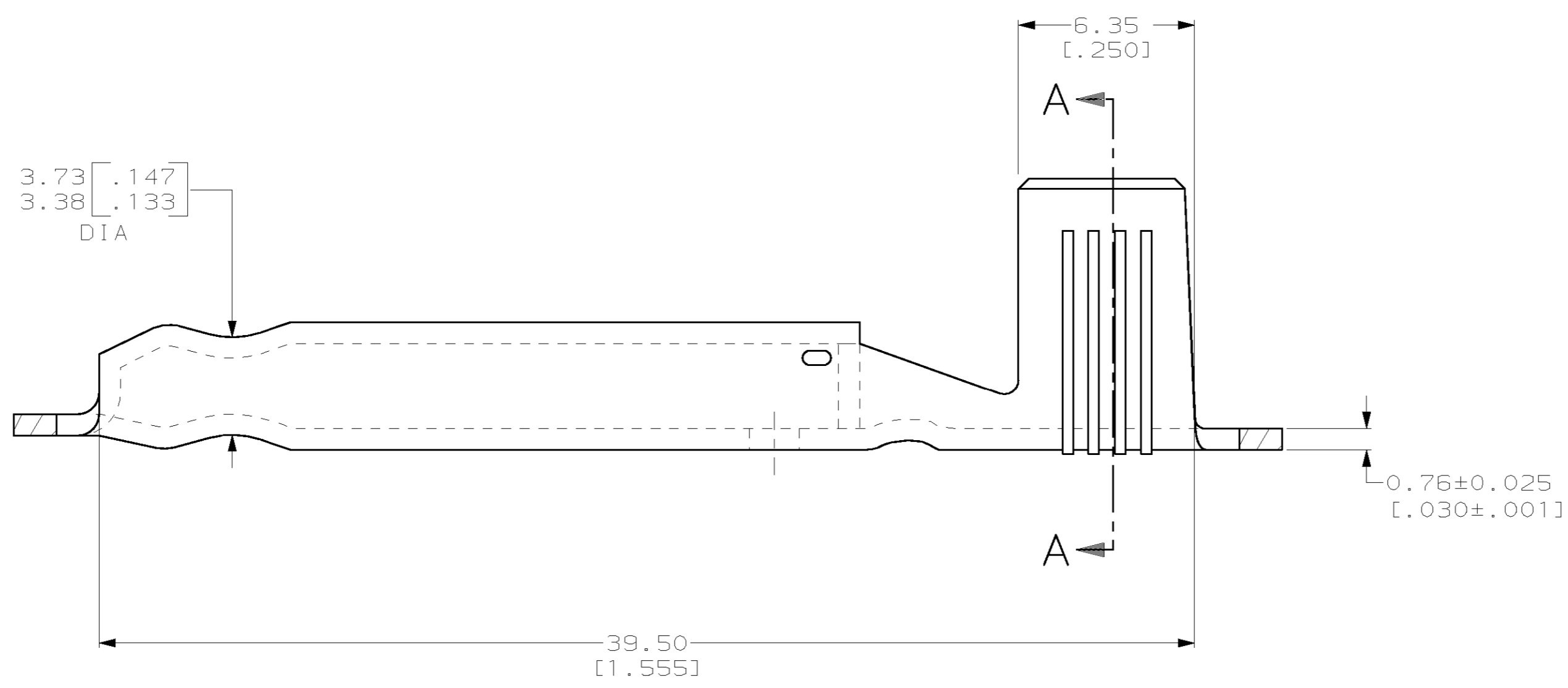
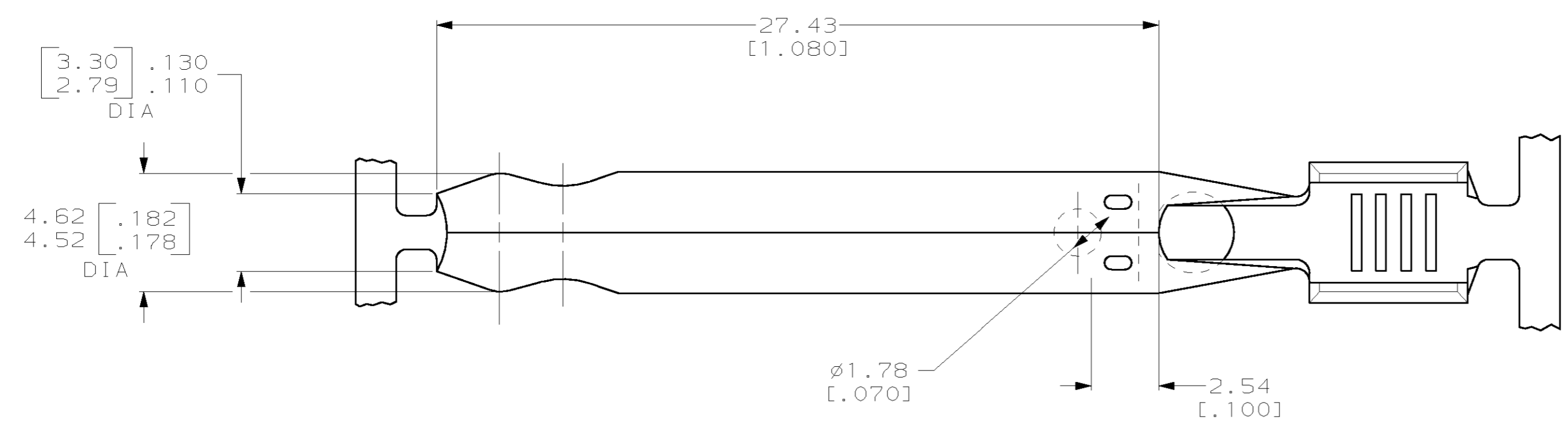

SECTION A-A

TWO #8'S AWG	1217185-1
WIRE RANGE	PART NUMBER

THIS DRAWING IS A CONTROLLED DOCUMENT.		DWN MICHAEL S. FEHER 04MAY1999	AMP Incorporated Harrisburg, PA 17105-3608	
DIMENSIONS: mm [INCHES]		CHK JEFF R. RUTH 05MAY1999	NAME RECEPTACLE, PLUG, 4.57 [0.180] DIA	
TOLERANCES UNLESS OTHERWISE SPECIFIED: 0 PLC ±- 1 PLC ±- 2 PLC ±0.25 [0.010] 3 PLC ±- 4 PLC ±- ANGLES ±-		APVD DONALD DECKER 05MAY1999	DRAWING NO A2 00779 C- 1217185	
MATERIAL 081 BRASS		FINISH 0.002032 [0.000080] MIN TIN PLATE	WEIGHT -	RESTRICTED TO -
CUSTOMER DRAWING		SCALE 6:1	SHEET 1 OF 1	REV A

1217185